

Wi-Safe 2 Strobe and Vibrating Pad Alert System

Product Image

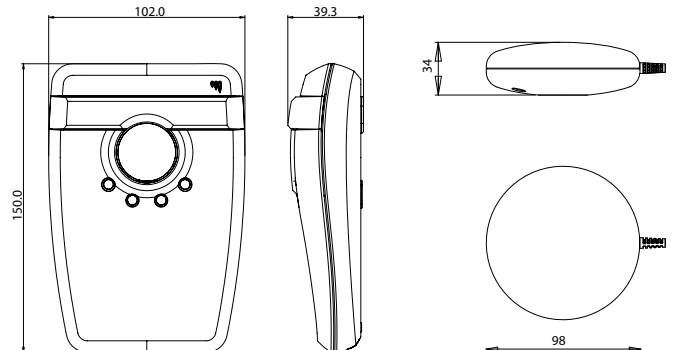

Product Dimensions (mm)



Model Number	W2-SVP-630
Retail Description	N/A
Retail EAN Number	N/A
Retail Packaging Format	N/A
Retail Packaging Dimensions WxHxD	N/A
Retail Packaging Weight	N/A
Retail SRP Quantity	N/A
Trade Description	Wi-Safe 2 Strobe and Vibrating Alert System
Trade EAN Number	O816317002305
Trade Packaging Format	Recycled cardboard box
Trade Packaging Dimensions WxHxD	195mm x 105mm x 70mm
Trade Packaging Weight	65g
Trade Outer Box Quantity	10
Warranty	5 years
Technology	Wi-Safe 2
Operation AC/DC	AC/DC
Battery Type	Removeable, rechargeable NiMH
Product Weight	457g (Including Strobe and Vibrating Pad, AC mains adaptor, manual, batteries and fixings)
Unit Dimensions (max) WxHxD (mm)	Strobe = 102 x 150 x 39.3 Vibrating pad = 98 x 98 x 34

Alert Type	Vibrating pad and flashing strobe with LEDs
Operating Temperature	-4°C to +38°C
Operating Humidity	Up to 90% RH non condensing
Installation Positions	Vibrating pad under pillow, mattress or seating cushion. Flashing strobe on wall or surface
Standards	BS 5446-3 : 2005 (Pending)

Health & Safety Information

Storage Temperature	-20°C to +60°C
Storage Humidity	Up to 93% RH% non-condensing
Storage Licensing Requirement	N/A
Isotope Activity	N/A

Wireless features (Wi-Safe 2)

Operating Frequency	868 MHz
Max no. of connected units (network)	50 units
Networking	Multi-directional communication
Compatibility	Compatible with all FireAngel Wi-Safe 2 products
Range	35m (over 200m in clear air)

